

X-RAY INSPECTION

SC



OCS PERFECTLY MEETS THE **REQUIREMENTS**
OF THE **GLOBAL FOOD INDUSTRY** THROUGH
ITS STATE OF THE ART **INSPECTION SOLUTIONS**

X-RAY TECHNOLOGY FROM OCS: MODULAR DIVERSITY FOR BEST POSSIBLE PROCESS AND PRODUCT SAFETY

CONTENT

3 **Advanced X-ray technology from OCS**

Ensuring product safety and brand protection are our biggest priorities

4 **OCS Checkweighers**

All required expertise under one roof: globally respected, flexible, and innovative

6 **The most advanced inspection systems**

X-ray technology from OCS

7 **Modular design**

For maximal economy

8 **SC-E**

High-tech X-ray scanner for professional detection of contaminants

10 **SC-Series**

Top performance with the greatest flexibility

12 **SC-B**

The most accurate inspection of bulk materials - the safety check for raw goods

14 **SC-S**

Compact and reliable inspection of standing products

16 **SC-W**

Twice as safe: X-ray scanner and checkweigher in combination

18 **SC-V**

X-ray and optical inspection in a compact unit

20 **OCS image processing software**

For maximal product and consumer safety

22 **X-ray quality features**

The advantages of OCS inspection systems

23 **Reliable expert service**

Our network of comprehensive know-how is on hand to support you worldwide

” X-ray scanners from OCS Checkweighers are a fixed element of our production processes, ensuring our customers of the highest standards of safety and products free of impurities.

The scanners deliver top performance with impressive detection accuracy and minimal product loss from mistaken ejection.”

Carlo Cotti and Marzio Tellini,
Executive Managers at Liodry Foods,
Gattatico, Italy



ADVANCED X-RAY TECHNOLOGY FROM OCS: ENSURING PRODUCT SAFETY AND BRAND PROTECTION ARE OUR BIGGEST PRIORITIES

In the industrial manufacturing of products, quality must be given the highest priority in all production processes. Against the backdrop of utmost concern for customer safety, supplying defective goods can quickly result in fatal consequences. Recall actions are extremely costly and may irreparably damage your image as a reliable producer. Even worse are the health risks passed on to the consumer because defective products were shipped.

OCS INSPECTION SYSTEMS - GUARANTEE OF QUALITY

To ensure the shelves at the retailer do not become a safety risk, manufacturers need advanced and fully automated inspection systems that reliably and continuously guarantee quality without restricting productivity.

OCS is among the leading suppliers of comprehensive inspection systems worldwide. Our globally recognised cutting edge technology and our comprehensive product range of ultra-modern, high performance X-ray scanners give you the

confidence of knowing you are in the best possible position in terms of quality assurance. Together with you, we create the foundation for sustained customer loyalty.

X-ray scanners from OCS support the efficient design of quality assurance systems on the basis of standards like HACCP, BRC, or IFS. These high-tech machines detect foreign bodies made of metal, glass, stone and plastics of different densities while checking your products for completeness, correct form and fill quantities.



- SC** **Scanning** – Premium X-ray inspection for high performance applications
- E** **Essential** – X-ray inspection for basic applications, best price-performance ratio

ALL THE EXPERTISE UNDER ONE ROOF: MEET OCS CHECKWEIGHERS

HEADQUARTERS WIPOTEC GROUP



OCS Checkweighers is a fully owned subsidiary of the high-tech specialist Wipotec. The dynamic, fast, and highly accurate weighing and inspection systems from both companies have been the reliable standard for more than 25 years. OCS has provided solutions in the production lines of leading producers in the pharmaceutical, food, chemical, and cosmetics industries, in addition to the mail and logistics sectors.

EXCELLENCE IN STANDARD AND CUSTOM-BUILT MACHINES

Wipotec and OCS stand for sophisticated high-tech systems with maximum ease of use. The impressive product portfolio provides solutions for nearly all customer applications. If necessary, we take special requirements and conditions into account in supplying customised equipment.

EXTRAORDINARY MANUFACTURING DEPTH, ALL SIDE BY SIDE

OCS contributes great importance to the in-house development of all necessary technologies as well as the in-house manufacturing of all core components. Consequently, we develop a depth of manufacturing that differentiates us from other vendors and makes us largely independent of suppliers, while forming the basis for our delivery reliability.

At OCS, the entire value chain from basic research, to planning, design, and manufacture to sales and service is all under one roof. The benefit of short channels of communication is the guarantee of maximum flexibility in the implementation of every individual product configuration. No matter how unusual your application may be, we will show you a possible solution that is sure to convince you. That's what makes the difference!



GLOBALY RESPECTED, INDEPENDENT, FLEXIBLE, AND INNOVATIVE: THAT IS OCS

- ☑ GLOBALLY RESPECTED PARTNER IN INDUSTRY FOR MORE THAN 25 YEARS
- ☑ WORLDWIDE PRESENCE THANKS TO NUMEROUS SUBSIDIARIES AND PARTNERS
- ☑ FOUNDER MANAGED COMPANY
- ☑ COMPANY WITH HIGH INNOVATION POWER THROUGH LARGE R&D EFFORT, INCL. BASIC RESEARCH
- ☑ ALL EXPERTISE COMBINED UNDER ONE ROOF
- ☑ IN-HOUSE PRODUCTION OF ALL KEY COMPONENTS
- ☑ BROAD PRODUCT RANGE FOR ALMOST EVERY APPLICATION
- ☑ BROAD RANGE OF EXPERTISE IN IMPLEMENTING CUSTOMER-SPECIFIC INSPECTION SYSTEMS
- ☑ USE OF HIGH PRECISION WIPOTEC WEIGHING SYSTEMS FOR OPTIMUM PRODUCT QUALITY
- ☑ MEMBER OF THE EUROPEAN HYGIENIC ENGINEERING & DESIGN GROUP (EHEDG)
- ☑ OUTSTANDING SERVICE CAPABILITIES

COME AND VISIT US!

Interested in the high-tech solutions from OCS? Perhaps you would like to visit our ultra-modern plant. Our prominent market position is no accident, but rather the logical consequence of the creative and competent efforts made by our staff on behalf of our customers. Come and see for yourself. Just schedule an appointment for a tour with us!

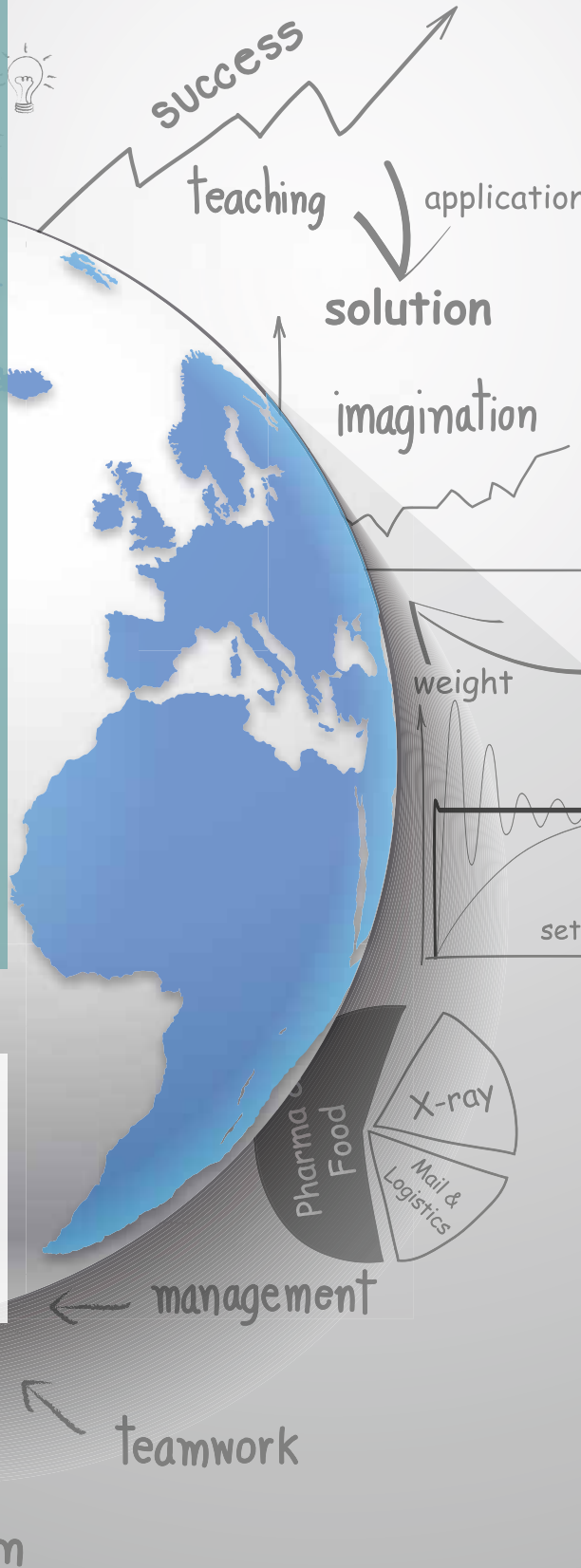

POWERFUL X-RAY TECHNOLOGY FROM OCS

The prerequisite of a successful detection of foreign bodies are X-ray images of the highest quality. It begins with the selection of the optimal X-ray source in combination with the best sensors and high performance image processors running the software. The modular system of OCS X-ray technology encompasses air-cooled monoblocks as well as water-cooled metal ceramic tubes with beryllium windows.

The adjustable high voltage generator drives the x ray tube. Using a collimator, it sends a concentrated beam of radiation to the high performance camera. The product to be inspected is positioned on the integrated belt conveyor between the X-ray tube and the camera where it is then x-rayed.

The resulting high resolution X-ray images correspond to the specific density profiles of the controlled products. Foreign bodies within the product are then detected on the basis of their higher specific densities.

The X-ray images are displayed in real time on the 15" touch-screen control panel. Simultaneously, by means of in-house developed image processing software, they are checked against a number of possible defects like impurities, product deformation, fill level deviation, and incomplete or broken products.

Defective products are removed from the production flow with the aid of any one of a variety of alternative mechanisms. The ejection crosscheck control (optional) reliably monitors this process. In the interest of full traceability, the images of the ejected products are archived with a date and time stamp in the image data memory.

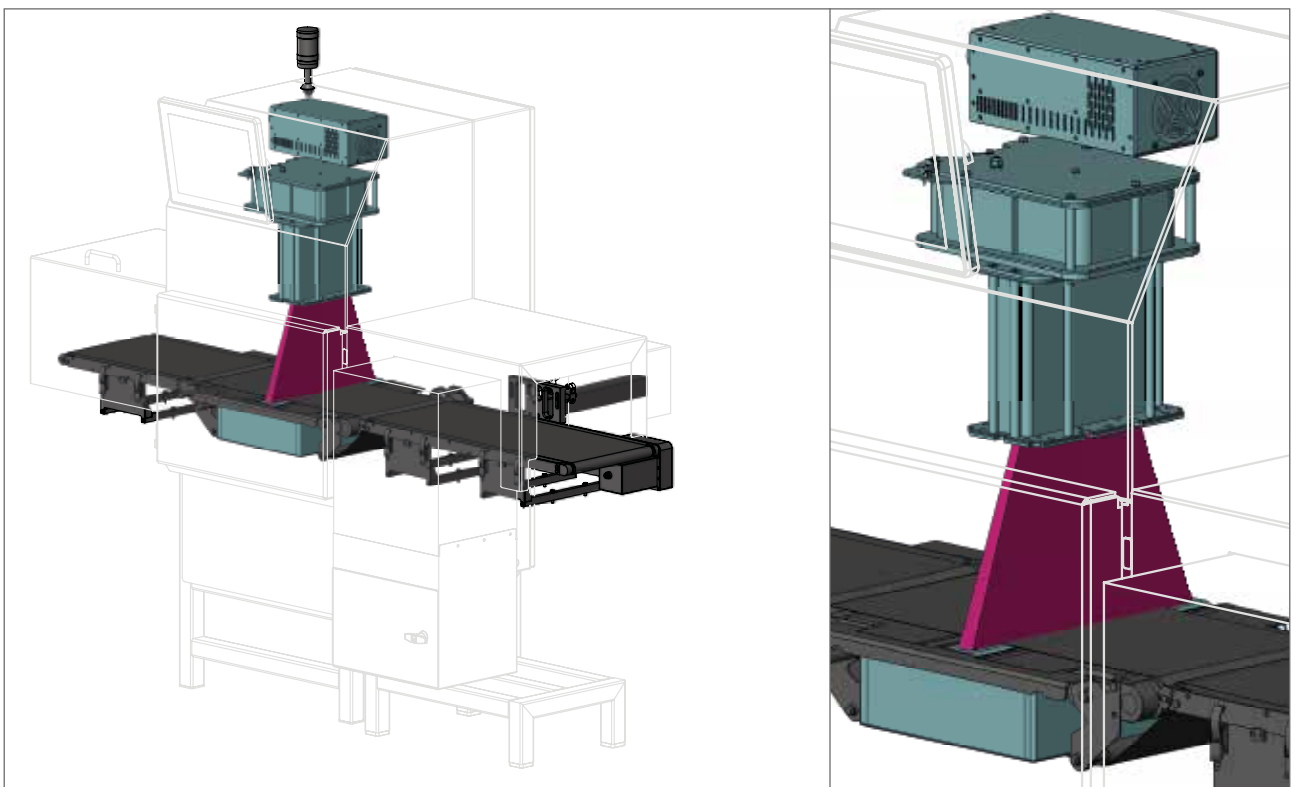

Vertical X-ray beam (penetrating the inspected product) processed by the high performance camera

MODULAR DESIGN FOR TAILOR-MADE SOLUTIONS

Thanks to their modularity, the X-ray scanners of the SC-series are, in a single word, economical. Looking at each individual customer application, OCS builds optimally customised machines in a hygienic design that provide sustained support to customers in their pursuit of maximal productivity and product security.

That is the reason for so many different variants regarding X-ray technology, conveying technology, and accessories. For our customers, that means the greatest possible flexibility in the product configuration. The initial basis for the perfect inspection system is always a space saving core segment, easy to integrate in every line that can be supplemented by those components that are most practical for use in your individual environment.

It is not necessary to position the products with the required distances between them, in advance. The modular system design of OCS X-ray scanners is unique on the market in that it automatically sets the required product distances for the inspection. This advantage significantly reduces your investment costs. In many cases, it is what makes the installation of the X-ray technology possible.



Basis of the modular system: the core segment



Core segment inspects bulk product



Core segment curtain-free with multi lane product processing



Core segment inspects large, chunky products

HIGH-TECH X-RAY SCANNER FOR PROFESSIONAL DETECTION OF CONTAMINANTS

SC E

The **SC-E** is the perfect entry to the world of ultra-modern X-ray inspection systems and the associated high quality product line of OCS. Designed and developed to meet the most stringent requirements of foreign body detection, with an optional comprehensive software package, the scanner becomes an excellent all-rounder that reliably performs count, completeness, and fill-level control checks. Together with the intelligent software tool (optional) for hiding packaging clips, the SC-E proves to be an exemplary inspection system.

The compact SC-E includes a Diode Array Detector with a 0.4 mm resolution, even in the basic version, and the machine is very easy to integrate in any existing production line.

All of the X-ray scanners from OCS have the same familiar and convenient user interface found in the checkweigher line. The system is controlled from a 15" colour TFT display with touchscreen panel that always shows the current X-ray image. Designed for protection class IP65 with full stainless steel construction, the system features a balcony design and sloped surfaces that, together with the C-shaped

product area, enable thorough cleaning quickly and easily. All scanners meet the most stringent standards of hygiene.

The SC-E product series is more than a good investment for all users who are looking for highly professional foreign body detection. It represents a well-engineered, technical and economical solution at a highly competitive price.



MAIN FEATURES

- ✔ Compact design
- ✔ Diode Array Detector with 0.4 mm resolution
- ✔ Comprehensive software package (optional)
- ✔ Numerous sorting systems (optional)
- ✔ For all primary and secondary packaging up to medium size

YOUR BENEFITS

- ✔ Reliable all-rounder for optimal productivity
- ✔ Compact design for easy integration

TECHNICAL DATA

X-ray type	monoblock, air cooled
X-ray output	up to 200 W (infinitely variable)
X-ray sensor	Diode array technology with 0.4 mm resolution
Scanning width	300 mm
Scanning speeds	60 m/min (optional up to 90 m/min)
Product storage	100 products, expandable
Display	15" colour TFT with touchscreen
Working height	750-850 mm, 800-900 mm, 850-950 mm ¹⁾
Scanner belt lengths	800 / 1,500 / 1,800 mm
Weight	approx. 400 kg
Hygienic design	Complete stainless steel model (1.4301); easy to clean product area; built-in drive technology
Ambient conditions	+5°C to +35°C (optional 40°C), relative humidity 30% - 85%
Protection class	IP65
Power supply	230 V, AC/50Hz, 1.6 kVA Connection with separate, 16 A fuse power line



Hygienic design through chamfered surfaces



Detachable hoods enable easy cleaning

1) Other heights available by request



Other machine specifications
→ Technical Data Sheet



TOP PERFORMANCE WITH THE GREATEST FLEXIBILITY

SC
3000
4000
5000
6000

The globally successful **SC** product line meets the highest standards of modern quality management. Nothing is left to chance in terms of process safety and hygienic design. A high performance camera detector equipped with HD-TDI technology ensures high resolution and sharp X-ray images, while providing the optimal basis for the image processing software developed at OCS. The minimal faulty rejection rate combines with the maximal detection accuracy to provide the greatest possible safety.

The core of the scanner is its sensor. A highly sensitive HD-TDI camera detector in conjunction with the metal ceramic tube generates an X-ray image marked by an extremely high resolution.

Each model is equipped with a comprehensive software package. The scope of performance of this network-enabled scanner includes foreign body detec-

tion, quantity, shape, completeness, and fill level control. The scanning process is continuously documented and is available for single and multi-track systems.

All of the X-ray scanners from OCS have the same familiar and convenient user interface found in the checkweigher line. The system is controlled from a 15" colour TFT display with touchscreen panel that

always shows the current X-ray image. Designed for protection class IP65 with full stainless steel construction, the system features a balcony design and sloped surfaces that, together with the C-shaped and weldless product chamber, enable thorough cleaning quickly and easily. All scanners meet the most stringent standards of hygiene.



MAIN FEATURES

- ✔ C-shaped product chamber
- ✔ Flexible component design
- ✔ Compact design
- ✔ Integrated conveyor systems
- ✔ Balcony design
- ✔ High performance camera detector with HD-TDI technology

YOUR BENEFITS

- ✔ The broadest inspection for maximum safety
- ✔ Compact design for easy integration

TECHNICAL DATA

X-ray type	Metal-ceramic tube with integrated water cooling system or air-cooled monoblock
X-ray output	up to 600 W, depending on type (infinitely variable)
X-ray sensor	Long-life camera technology with 160 µm resolution
Scanning width	from 300 to 600 mm ¹⁾
Scanning speeds	up to 120 m/min
Product storage	100 products, expandable
Display	15" colour TFT with touchscreen (19" optional)
Working height	750-850 mm, 800-900 mm, 850-950 mm ²⁾
Weight	approx. 500 kg
Hygienic design	Complete stainless steel model (1.4301), easy to clean product area, built-in drive technology
Ambient conditions	+5°C to +40°C, relative humidity 30% - 85%
Protection class	IP65, IP69K ³⁾
Power supply	230V, AC/50Hz, 2.5kVA (altern. SC 6000: 400V, AC/50Hz, 3.5 kVA) Connection with separate, 16 A fuse power line (SC 6000: 10A)



High performance x ray tube for an excellent product penetration



C shape product chamber for the highest hygienic requirements

- 1) Wider models available by request
- 2) Other working heights by request
- 3) By request



Other machine specifications
→ Technical Data Sheet



MOST ACCURATE INSPECTION OF BULK MATERIALS: THE SAFETY CHECK FOR RAW GOODS

SC B

The optimal technical support for starting your production process with a quality control check of the raw goods - the **SC-B** model. The scanner provides a very high detection sensitivity that checks loose materials of any kind for the presence of foreign objects. You can be sure that if there is an impurity in the product, it will not be allowed to enter your production process.

The SC-B has the appropriate ejection system to guarantee reliable detection of contaminants with only minimal product loss. The scanner is available in different scanner band widths to efficiently support your individual, long-term line requirements. Meet your customers' expectations regarding product quality with the help of SC-B that guarantees the highest

detection sensitivities in terms of foreign object identification and prevention.

All of the X-ray scanners from OCS have the same familiar and convenient user interface found in the checkweigher line. The system is controlled from a 15" colour TFT display with touchscreen panel that always shows the current X-ray image.

Designed for protection class IP65 with full stainless steel construction, the system features a balcony design and sloped surfaces that, together with C-shaped product area, enable thorough cleaning quickly and easily. All scanners meet the most stringent standards of hygiene.



MAIN FEATURES

- ✔ Flexible component design
- ✔ Compact design
- ✔ Integrated conveyor systems
- ✔ Balcony design
- ✔ Extensive range of ejection systems

YOUR BENEFITS

- ✔ Reliable check of incoming goods for highest product quality
- ✔ Greatest flexibility for optimal line integration

TECHNICAL DATA

X-ray type	Metal-ceramic tube with integrated water cooling system or air-cooled monoblock
X-ray output	up to 600 W, depending on type (infinitely variable)
X-ray sensor	Long-life camera technology with 160 µm resolution
Scanning width	from 300 to 600 mm ¹⁾
Scanning speeds	up to 120 m/min
Product storage	100 products, expandable
Display	15" colour TFT with touchscreen (19" optional)
Working height	750-850 mm, 800-900 mm, 850-950 mm ²⁾
Weight	approx. 500 kg
Hygienic design	Complete stainless steel model (1.4301); easy to clean product area, built-in drive technology
Ambient conditions	+5°C to +40°C, relative humidity 30% - 85%
Protection class	IP65, IP69K ³⁾
Power supply	230V, AC/50Hz, 2.5kVA (altern. SC-B 6000: 400V, AC/50Hz, 3.5 kVA) Connection with separate, 16 A fuse power line (SC-B 6000: 10A)

- 1) Wider models available by request
- 2) Other working heights by request
- 3) By request



Other machine specifications
→ Technical Data Sheet



Numerous reject flaps ensuring minimal product loss



Optimal transport of bulk products through troughed belts



Outfeed conveyor in reversing mode (right) for smallest reject rates



Reversing mode

COMPACT AND RELIABLE INSPECTION OF STANDING PRODUCTS

SC S

If you have to check standing products for impurities by means of X-rays and ensure the correct fill levels, then the models of the **SC-S** series are the perfect choice.

These models follow a component design that enables an easy, space-saving integration with any existing production line. The sideview scanner reliably checks cans, bottles, composite packaging, paper, or plastic containers. Either a belt or a chain conveyor can pass through the scanner's housing.

All of the X-ray scanners from OCS have the same familiar and convenient user interface found in the checkweigher line. The system is controlled from a 15" colour TFT display with touchscreen panel that always shows the current X-ray image. Designed for protection class IP65 with full stainless steel construction, the system

features a balcony design and sloped surfaces that, together with C-shaped product area, enable thorough cleaning quickly and easily. All scanners meet the most stringent standards of hygiene.



MAIN FEATURES

- ✔ Flexible component design
- ✔ Checks standing products like cans, bottles, PVC containers
- ✔ Compact design
- ✔ Integrated conveyor systems

YOUR BENEFITS

- ✔ The broadest inspection for maximum productivity
- ✔ Compact design for easy integration

TECHNICAL DATA

X-ray type	Metal-ceramic tube with integrated water cooling system or air-cooled monoblock
X-ray output	up to 600 W, depending on type (infinitely variable)
X-ray sensor	Long-life camera technology with 160 µm resolution or diode array technology with 0.4 mm resolution
Scanning width	400 mm ¹⁾
Scanning speeds	up to 120 m/min
Product storage	100 products, expandable
Display	15" colour TFT with touchscreen (19" optional)
Working height	750-850 mm, 800-900 mm, 850-950 mm ²⁾
Weight	approx. 500 kg
Hygienic design	Complete stainless steel model (1.4301), easy to clean product area, built-in drive technology
Ambient conditions	+5°C to +40°C, relative humidity 30% - 85%
Protection class	IP65, IP69K ³⁾
Power supply	230 V, AC/50Hz, 2.5 kVA Connection with separate, 16 A fuse power line

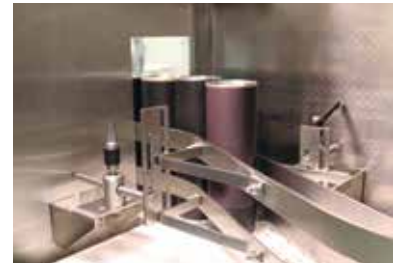

Secure material handling in product chamber

- 1) Wider models available by request
- 2) Other working heights by request
- 3) By request



Other machine specifications
→ Technical Data Sheet

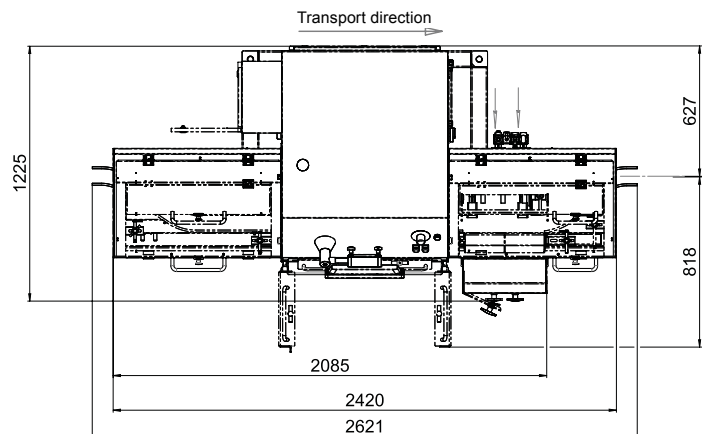
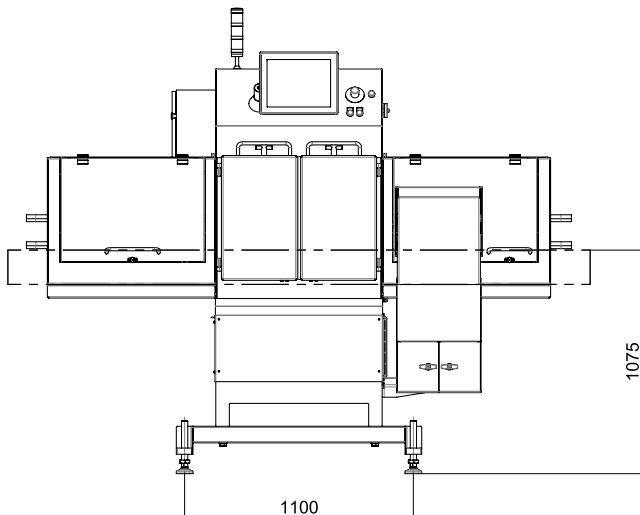
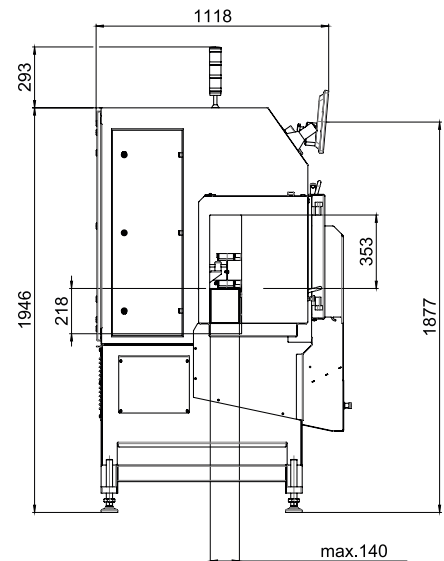

All entries in mm

CHECKWEIGHER AND X-RAY INSPECTION IN A SPACE SAVING UNIT

SC W

The **SC-W** series is a pioneering combination of innovative X-ray technology and the proven checkweigher technology from OCS. The products in the accepted goods stream are checked not only for impurities, but also undergo a high-precision weight control check. Units with an incorrect weight are ejected into a separate container.

Both the single and the dual-track model are very successful – either with or without the curtain for radiation protection. The variant without protective curtain provides high throughput rates of up to 300 pieces per minute per track, which is even possible for very lightweight product units.

The tool-free exchange of all conveyor belts and the easy to handle housing

make it really simple to clean the system. The product chamber is separated from all of the drive system components.

All of the X-ray scanners from OCS have the same familiar and convenient user interface found in the checkweigher line. The system is controlled from a 15" colour TFT display with touchscreen panel that always shows the current X-ray image and product weight.

Designed for protection class IP65 with full stainless steel construction, the system features a balcony design and sloped surfaces that, together with C-shaped product area, enable thorough cleaning, quickly and easily. All scanners meet the most stringent standards of hygiene.



MAIN FEATURES

- ✔ X-ray scanner and checkweigher in one unit
- ✔ Flexible component design
- ✔ Available as single or dual-track system

YOUR BENEFITS

- ✔ X-ray scanner and checkweigher for maximum product safety
- ✔ Easy to operate central user interface

TECHNICAL DATA

X-ray type	Metal-ceramic tube with integrated water cooling system or air-cooled monoblock		
X-ray output	up to 600 W, depending on type (infinitely variable)		
X-ray sensor	Long-life camera technology with 160 µm resolution		
Scanning width	from 300 to 600 mm ¹⁾		
Scanning speeds	up to 120 m/min with up to 300 products per track		
Product storage	100 products, expandable		
Display	15" colour TFT with touchscreen (19" optional)		
Working height	750-850 mm, 800-900 mm, 850-950 mm ²⁾		
Weight	approx. 500 kg		
Hygienic design	Complete stainless steel model (1.4301), easy to clean product area; built-in drive technology		
Ambient conditions	+5°C to +40°C, relative humidity 30% - 85%		
Protection class	IP65		
Power supply	230 V, AC/50Hz, 2.5 kVA Connection with separate, 16 A fuse power line		
Weighing technology	Gross weight range	Max. preload	Min. calibration value
Single track	750-7,500 g	4,000-15,000 g	0.1 g
Dual track	750-7,500 g	4,000-15,000 g	0.1 g
Max. output³⁾	300 ppm		
Certification	DE-08-MI006-PTB028 (MID)		
Standard deviation (1s)³⁾	> 50 mg		



Comprehensive product inspection:
X-Ray and weighing in combination

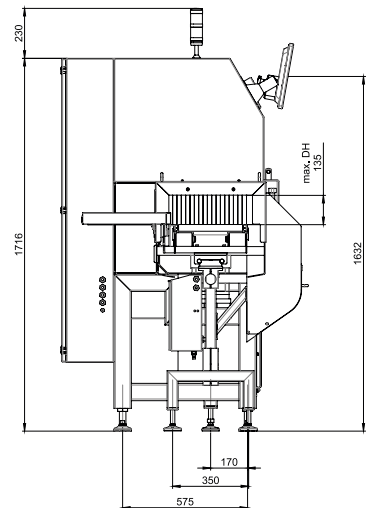

- 1) Wider models available by request
- 2) Other working heights by request
- 3) Dependent on product form, product behaviour, transport speed, and local conditions



Other machine specifications
→ Technical Data Sheet

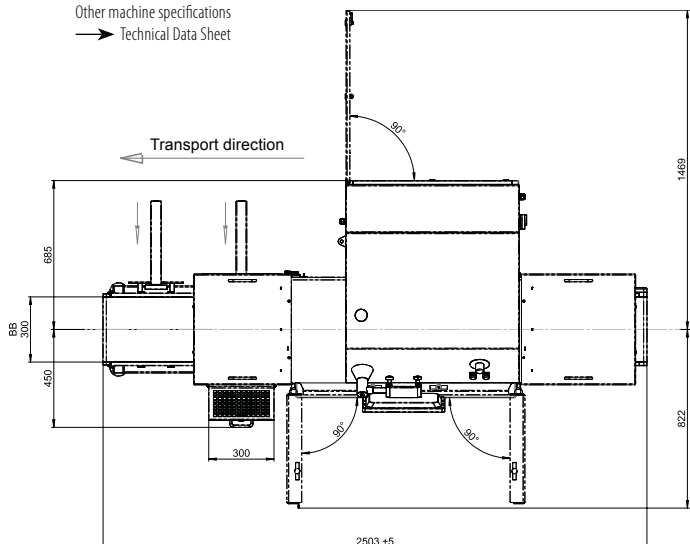
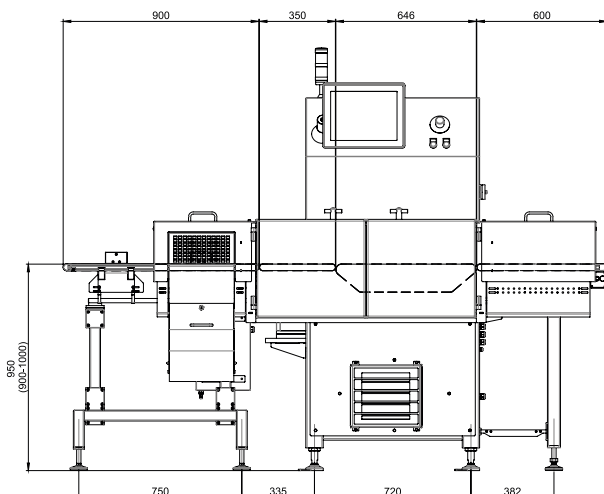

All entries in mm

X-RAY AND OPTICAL INSPECTION IN A COMPACT UNIT

SC V

The **SC-V** model represents the most advanced inspection technology. It combines reliable detection of product impurities by means of the high performance X-ray scanner with additional optical control systems developed in-house at OCS.

These control systems check the information as it appears on the products (ingredients, nutritional values, expiry date) for correctness and a flawless appearance regarding the proper positioning and readability of all labels and seals. Both inspection units – X-ray system and optical control – are combined in one space-saving design.

In addition to the reliable detection of foreign bodies, the SC-V also guarantees the

accurate and uniform appearance of your products. The model constitutes an outstanding inspection system that provides maximum safety and prevents costly recalls resulting from product contamination or incorrect labelling.

This model has the same familiar and convenient user interface used in the checkweigher line. The system is controlled from a 15" colour TFT display with touch-screen panel that always shows the cur-

rent image. Designed for protection class IP65 with full stainless steel construction, the SC-V system features a balcony design and sloped surfaces that, together with C-shaped product area, enable thorough cleaning quickly and easily. This machine also meets the most stringent standards of hygiene.

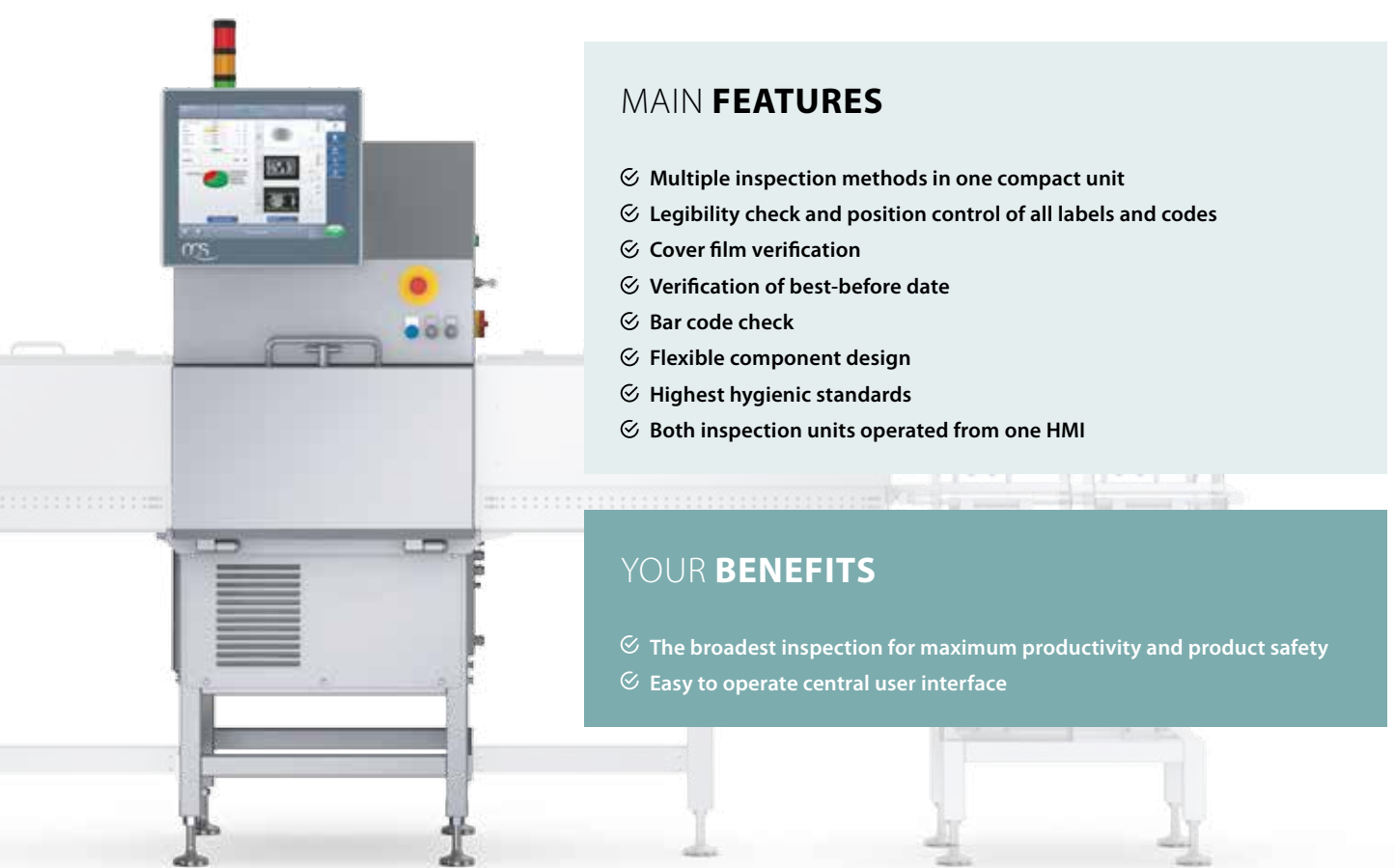

MAIN FEATURES

- ✔ Multiple inspection methods in one compact unit
- ✔ Legibility check and position control of all labels and codes
- ✔ Cover film verification
- ✔ Verification of best-before date
- ✔ Bar code check
- ✔ Flexible component design
- ✔ Highest hygienic standards
- ✔ Both inspection units operated from one HMI

YOUR BENEFITS

- ✔ The broadest inspection for maximum productivity and product safety
- ✔ Easy to operate central user interface

TECHNICAL DATA

X-ray type	Metal-ceramic tube with integrated water cooling system or air-cooled monoblock
X-ray output	up to 600 W, depending on type (infinitely variable)
X-ray sensor	Long-life camera technology with 160 µm resolution
Scanning width	from 300 to 600 mm ¹⁾
Scanning speeds	up to 70 m/min with 150 ppm (with inspection on both sides)
Product storage	100 products, expandable
Display	15" colour TFT with touchscreen (19" optional)
Working height	750-850 mm, 800-900 mm, 850-950 mm ²⁾
Weight	approx. 500 kg
Hygienic design	Complete stainless steel model (1.4301), easy to clean product area, built-in drive technology
Ambient conditions	+5°C to +40°C, relative humidity 30% - 85%
Protection class	IP54, IP65 ³⁾
Power supply	230 V, AC/50Hz, 3 kVA Connection with separate, 16 A fuse power line
Optical sensor	Black & white line sensor, colour available by request
Scanning width	300 mm ¹⁾
Sensor resolution	73 µm pixel size ⁴⁾



Optical Control: position and data contents of labels

- 1) Wider models available by request
- 2) Other working heights by request
- 3) By request
- 4) Smaller pixel sizes available by request



Other machine specifications
→ Technical Data Sheet

- 1 Optical control from below
- 2 X-ray inspection of foreign bodies
- 3 Optical control from the top down

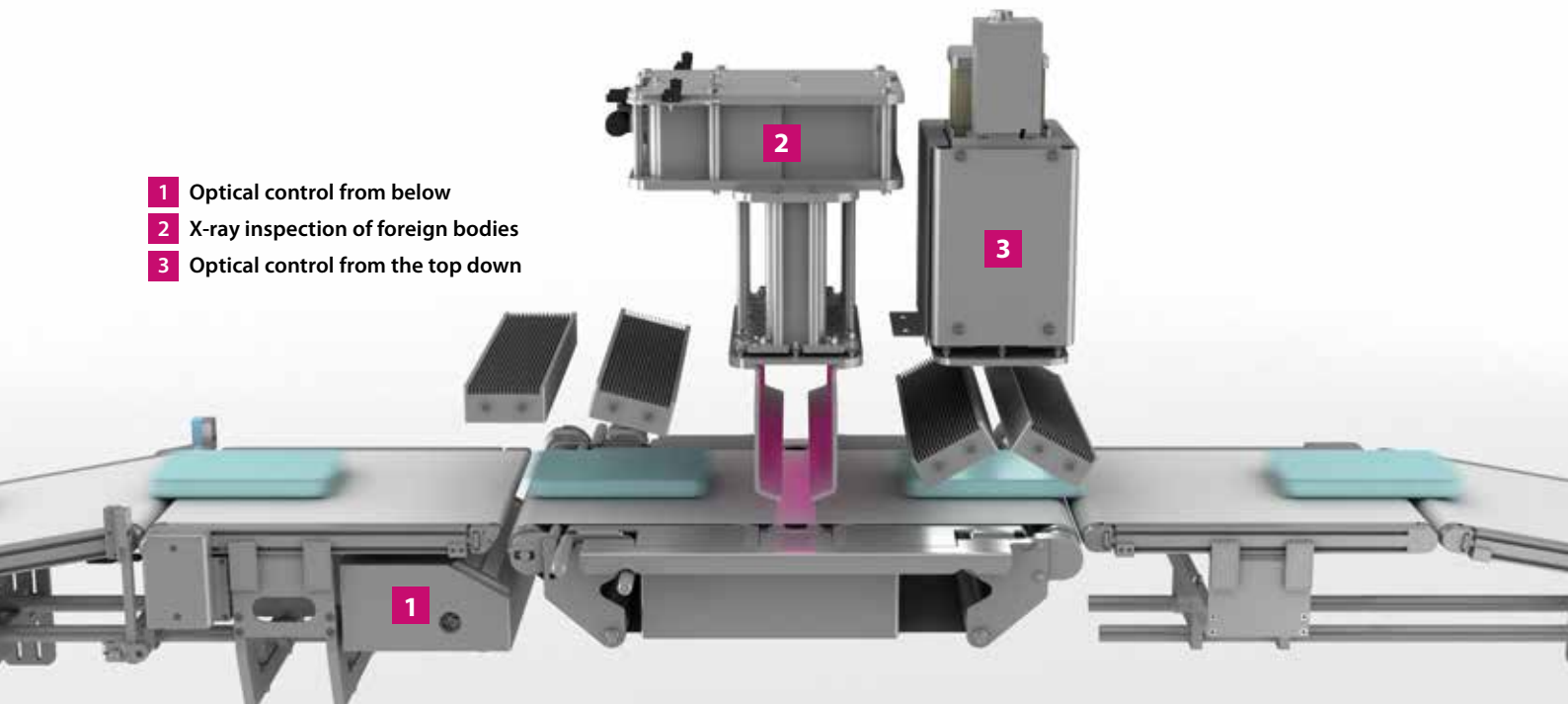

OCS X-RAY IMAGE PROCESSING SOFTWARE: FOR MAXIMAL PRODUCT AND CONSUMER SAFETY

The challenge facing today's market is the steadily increasing demand for quality and safe foods. Foreign objects like metal, glass, stone, bone, etc. pose a real threat to the health of the consumers. Quality features such as the completeness of the products, their perfect form and the correct fill level take on ever more significance.

Quality standards like HACCP, BRC, and IFC help to design an efficient quality assurance system with the primary aim being optimal product quality in addition to consumer safety. Achieving this without limiting productivity in today's production processes requires fully automated and reliable inspection systems.

Specialising in high precision product inspection and highly flexible in application, our component based inspection systems deliver an outstanding contribution to even greater safety for products and consumers.



Ready meals in tray

Foreign body scan
Quantity control

Fish in tray

Foreign body detection
Completeness control
(missing tray)

Yoghurt in tray

Foreign body detection
Fill level control
Completeness control

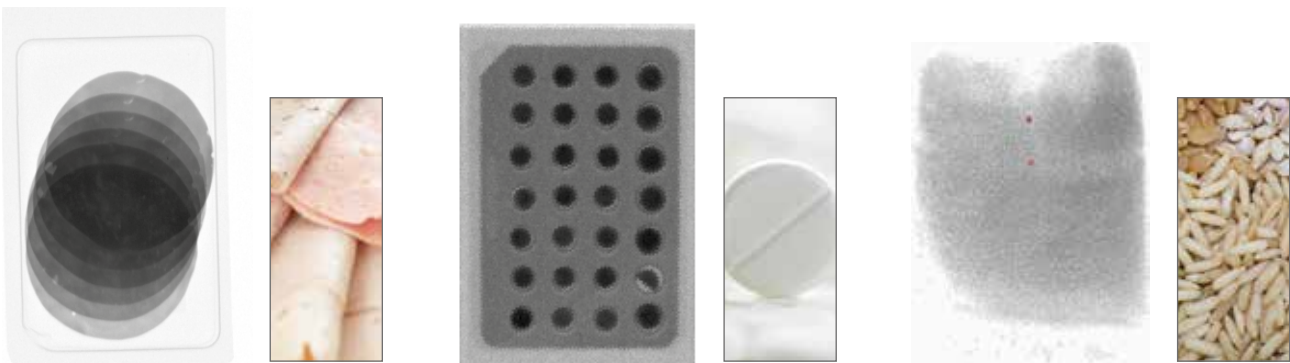

Cold meats, Sliced and packed in PVC

Foreign body scan

Drug products in blister pack

Foreign body detection
Completeness check
Broken product
Package leaflet control

Bulk materials, loose

Foreign body detection

COMPREHENSIVE INSPECTION: FOREIGN BODY DETECTION WITH CHECKS FOR COMPLETENESS, FORM, AND PROPER FILL LEVELS



Sausage/cold meats with clip seals

Foreign body detection
Clip and fill level control
Clip recognition (missing clip)

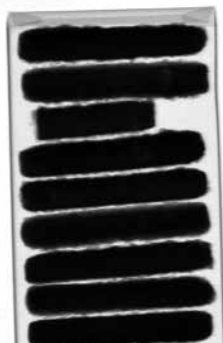

Fish sticks

Foreign body scan
Completeness check
Broken product

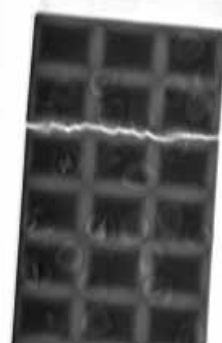

Chocolate

Foreign body detection
Broken product
Nut distribution
Completeness check

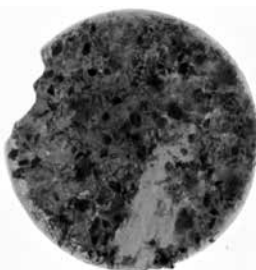

Pizza

Foreign body detection
Form check
Broken product
Surface control

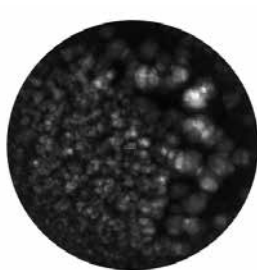

Cheese

Foreign body detection
Measuring density

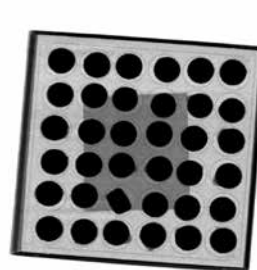

Praline box

Foreign body detection
Completeness check
Form control
Position check

THE QUALITY FEATURES OF POWERFUL X-RAY TECHNOLOGY

The inspection systems from OCS are successfully implemented worldwide. The reason for this is the use of high quality single components. They enable the efficient and reliable operations with the primary goal of maximising product safety and establishing your sustainable brand reputation through a consistently flawless product quality.

DIODE ARRAY DETECTOR

- ✔ High standard resolution of 0.4 mm
- ✔ 16-bit technology for
- ✔ Inspection speeds of up to 1.5m/s

FOR THE OPTIMAL DETECTION OF FOREIGN BODIES

CAMERA DETECTOR

- ✔ Multi-resolutions of 160 um
- ✔ 16-bit technology
- ✔ Inspection speeds of up to 2,0 m/s
- ✔ High resolution Time Delay Integration (HD-TDI)
- ✔ Wear-free

FOR HIGH RESOLUTION X-RAY IMAGES AND FURTHER INSPECTION FUNCTIONS

X-RAY UNIT

- ✔ Air-cooled monoblock
- ✔ Water-cooled metal-ceramic tube
- ✔ Closed cooling cycle (water)

FOR THE OPTIMAL CUSTOMISATION OF INSPECTION FUNCTIONS

DESIGN/CONSTRUCTION

- ✔ Balcony design with chamfered product chamber surfaces
- ✔ Product areas free from welded joints, in C-Form
- ✔ Modular construction
- ✔ Complete separation of product and machine areas

FOR SIMPLE INTEGRATION INTO EXISTING LINES, AND FOR THE HIGHEST OF HYGIENE REQUIREMENTS

COMMUNICATION AND NETWORK CAPABILITY

- ✔ Connection to ComScale
- ✔ Communication with upstream and downstream line aggregation
- ✔ Article change over a PLC (Allen Bradley and Siemens – optional)

FOR PERFECT LINE INTEGRATION AND THE CONTINUOUS AND PERMANENT STORAGE OF PRODUCTION DATA

UXS SOFTWARE

- ✔ Intelligent auto-learn function
- ✔ Intuitive menu navigation
- ✔ Chaotic multi-track operation (optional)
- ✔ Countless software tools operating simultaneously

FOR THE HIGHEST EFFICIENCY IN PRODUCT INSPECTION

OCS – DEPENDABLE EXPERT SERVICES, CUSTOMISED FOR YOUR NEEDS

When you choose OCS as your system supplier, you have the benefit of top quality service modules that incorporate the vast experience of our weighing and inspection system experts. Whether a pure consulting service or specific line and product support throughout the product life cycle, we are your reliable partner.

Turn to us with your requirements. We would be pleased to discuss the scope and effort of individual services in more detail with you. Trust in the experience and reliability of OCS.

BENEFIT FROM THE OUTSTANDING RANGE OF OCS-SERVICES

- ☑ 24/7* – HOTLINE AVAILABILITY
- ☑ GLOBAL SERVICE NETWORK WITH CERTIFIED OCS-TECHNICIANS FOR ON SITE SUPPORT
- ☑ PROFESSIONAL INSTALLATION AND OPTIMISATION BASED ON CUSTOMER NEEDS ENSURES SMOOTH START-UP
- ☑ EUROPEAN MANUFACTURER – INITIAL CALIBRATION, EXCHANGE, AND OVERHAUL OF CALIBRATED PARTS
- ☑ PREVENTIVE MAINTENANCE, SETUP, AND OPTIMISATION OF YOUR OCS-PRODUCTS
- ☑ FAST ON SITE REPAIRS USING ORIGINAL PARTS
- ☑ CALIBRATION CHECKS AND READJUSTMENT OF THE ENTIRE SYSTEM, IF REQUIRED
- ☑ GENERAL PRODUCT AND TARGET OBJECTIVE TRAINING TO IMPROVE EFFICIENCY
- ☑ REMOTE MAINTENANCE FIRST HAND (WITH APPROPRIATE HARDWARE) FOR URGENT JOBS

* On conclusion of a corresponding service agreement



INNOVATIVE, HIGH-END INSPECTION SYSTEMS FOR BETTER IMPROVED EFFICIENCY AND PRODUCTIVITY

DE

EN

ES

FR

IT



**WE ARE THE IDEAL PARTNER FOR ALL
YOUR NEEDS, FROM PRE-SALES
CONSULTING TO AFTER SALES SERVICE**



A Wipotec Company

Headquarters:
OCS Checkweighers GmbH
Adam-Hoffmann-Str. 26
67657 Kaiserslautern
Germany

T +49.631.34146-0
F +49.631.34146-8690
info.ww@ocs-cw.com
www.ocs-cw.com

Your **OCS-Local**
Partner



166502
All errors and omissions reserved. Data subject to modifications.
Stated trademarks are property of the respective owners.